

030-1850 Flush Mounted Paddle/ Handle-Rigid Locking



This flush mounted paddle handle with rigid locking paddle is a redesign of our popular 030-0850 Flush Mounted Paddle Handle. With a modernized look, it can be used in FMVSS 206 (ECE R11) applications, is power lockable and features a 4-point pivot plate and lock cam actuation.

DESIGNED FOR:

- Medium to heavy duty on-highway vehicle entrance doors
- Off-highway applications— construction, mining, forestry and agricultural
- On-highway— emergency vehicles

Global Locations:

TriMark Corporation
500 Bailey Avenue
P.O. Box 350
New Hampton, Iowa 50659
United States
Tel: 641-394-3188
Fax: 641-394-2392
1-800-447-0343
www.trimarkcorp.com

TriMark Europe
Cedar Court
Walker road
Bardon Hill
Coalville LE67 1GZ
United Kingdom
Tel: +44(0)1530 512460
Fax: +44(0)1530 512461
www.trimarkeu.com

TriMark (Xuzhou)
Building A5 Jingwu Road
Xuzhou Economic
Development Zone
Xuzhou, Jiangsu
221004 PR China
Tel: +86 516 8773 0018
Fax: +86 516 8773 0058
www.trimarkcn.com



TriMark. Interactive. Product. Selector



TriMark



TriMark Corporation



TriMark Corporation

6/24-10

FEATURES/BENEFITS:

- Automotive styling preferred by customers in the ambulance and fire truck market
- Multiple connection points for use on inside lock and power lock actuation
- Easy installation - do not have to maneuver large pivot plate through cut-out in the door
- Molded rubber housing gasket and o-rings on the axle for better water infiltration resistance
- Non-slip tape added for secure opening of the door

AVAILABLE:

- Left and right hand configurations available
- Includes gasket for flange of housing to provide resistance to water and dirt infiltration
- Handle can be keyed to match other TriMark door product with KeyOne™ Plus for a single-key system, keyed alike or provided non-locking
- Customized bezel/trim for unique look for customers with the request of an added logo
 - Bezel kits sold separately (part number 36784)

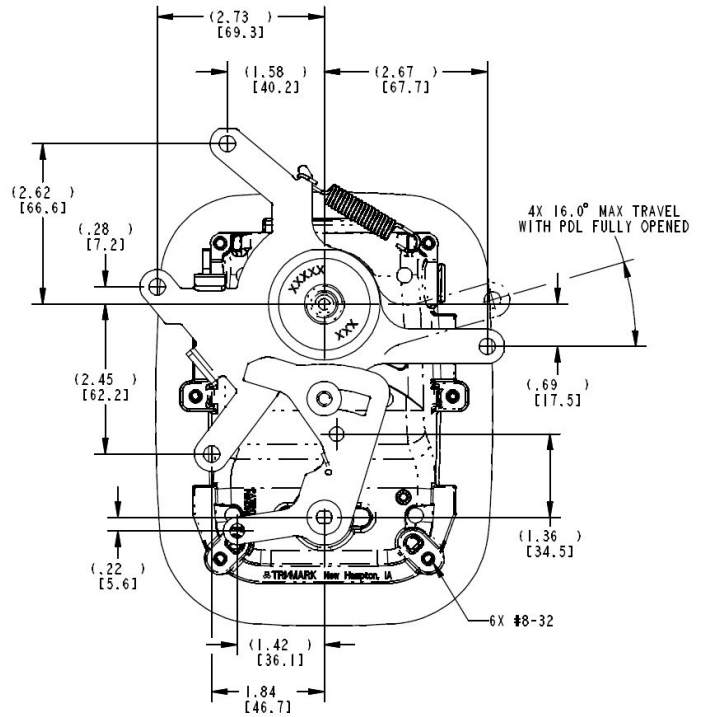
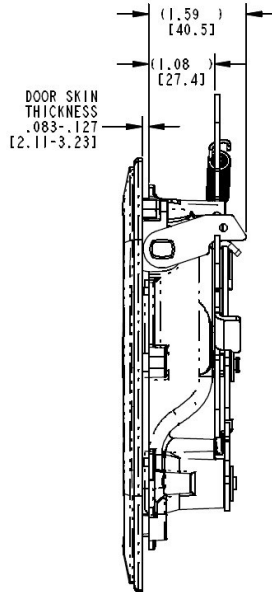
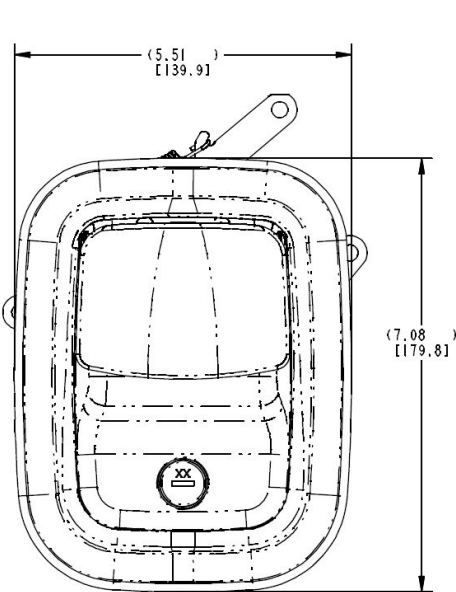

For more information visit
www.trimarkcorp.com

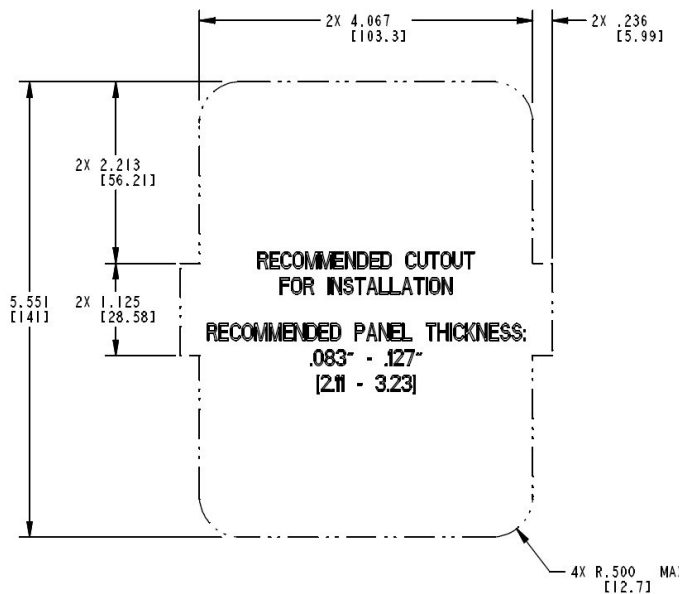

MATERIAL:

- Paddle and housing: Sturdy die cast zinc alloy
- Pivot components: Heat-treated, mild steel for wear resistance
- Bushing for paddle axle and thrust washer for pivot plate: Nylon 6/6

FINISH:

- Available in a variety of finishes including black powder coated, high quality buffed CNNC chrome or a combination of black/chrome finish

INSTALLATION:

- Design provides for easy installation without a mounting bracket with the use of (6) #8-32 fasteners
- Can be installed in a wide range of locations in door—either horizontal or vertical orientation (left hand shown)
- Installs into current 030-0850 cut-outs
- Door skin thickness - .083"-.127" (2.11mm-3.22mm)

Design Patent No. D694,087

U.S. Patent No. 10,024,085

Individual part dimensions are for reference only. Refer to individual part drawings for complete dimensions, specifications, and installation procedures. Engineering assistance and application drawings are available.

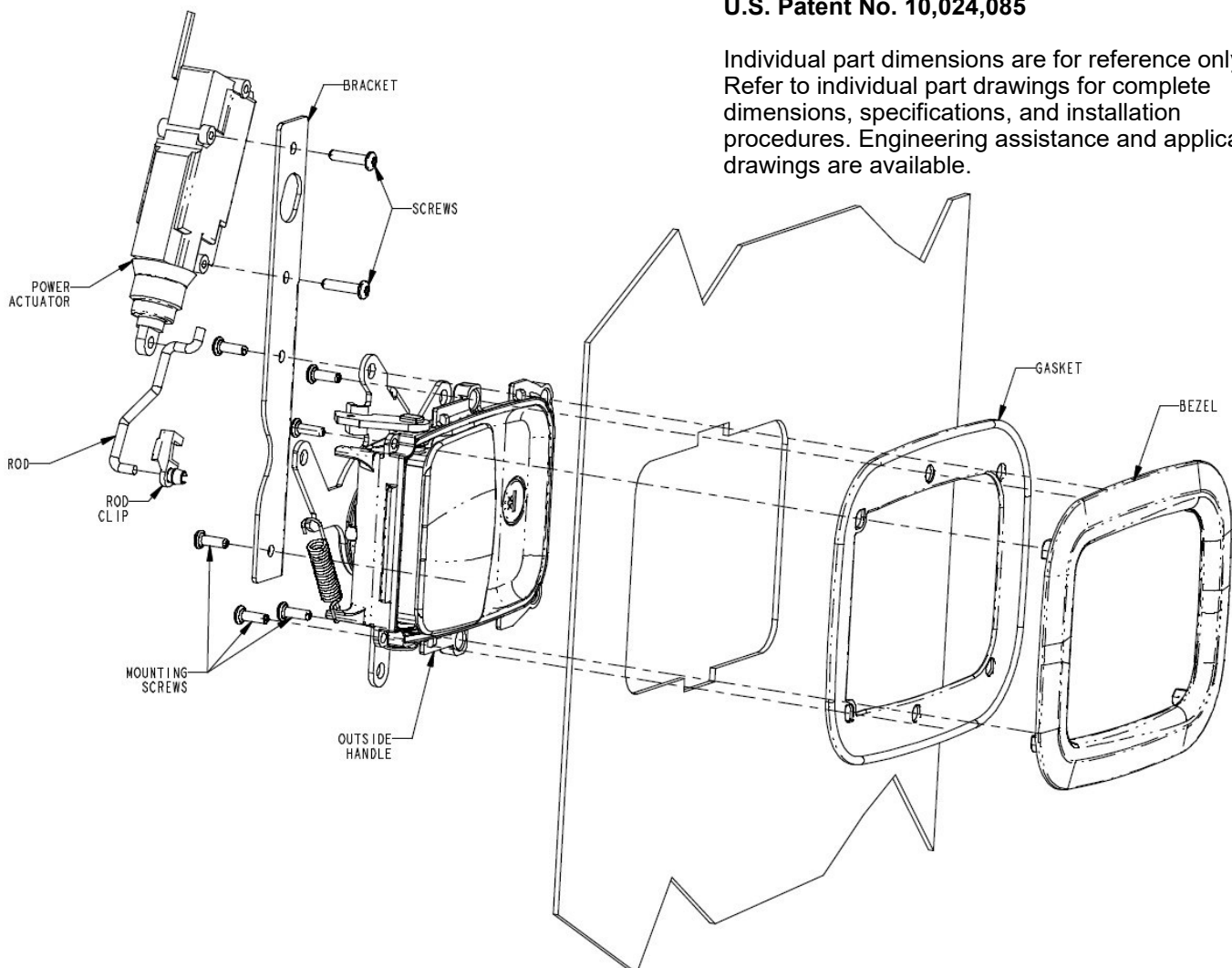

CAUTION: Applications of this product may fall within the requirements of FMVSS 206 (ECE R11) and SAE J839 safety standards. These safety related requirements are dependent on door application, e.g. front and rear hinged doors, sliding doors, or hinged upward swinging doors. The entire door hardware system must be included in the design/analysis process latch, handle, lock mechanism, cables/rods/linkages, fasteners, hinges, etc. This ensures compatibility of all components within the hardware system. If FMVSS 206 (ECE R11) is a requirement, then all of the components within the door system must comply with strength, inertia and locking requirements as specified within the Standard. Note that this product complies with FMVSS 206 (ECE R11) when tested in accordance with SAE J839 and that this product meets FMVSS 206 (ECE R11) locking requirements and may be used in FMVSS 206 (ECE R11) applications pending TriMark application approval.